

LAMINATION OF LVL

The details below are applicable for LVL beams supplied by Meyer Timber® which have been designed as double or triple members. The recommended fixings are highlighted in red in the tables below.

Nail Lamination Notes:

- Each lamination shall be the same thickness (2/35mm, 3/45mm, 2/63mm, 2/70mm etc).
- A bead of elastomeric adhesive should be placed along both the top and bottom edges to prevent moisture penetration between the laminates.
- At locations of high point loads into the beam ensure the bracket fasteners penetrate into all laminations or provide additional fixings.
- Bolted assemblies require 50x50 timber washers to be installed both sides.
- The top edge of the laminated beam should be kept dry and weather protected.
- Take care with end of nails or screws that may be longer than total beam thickness.

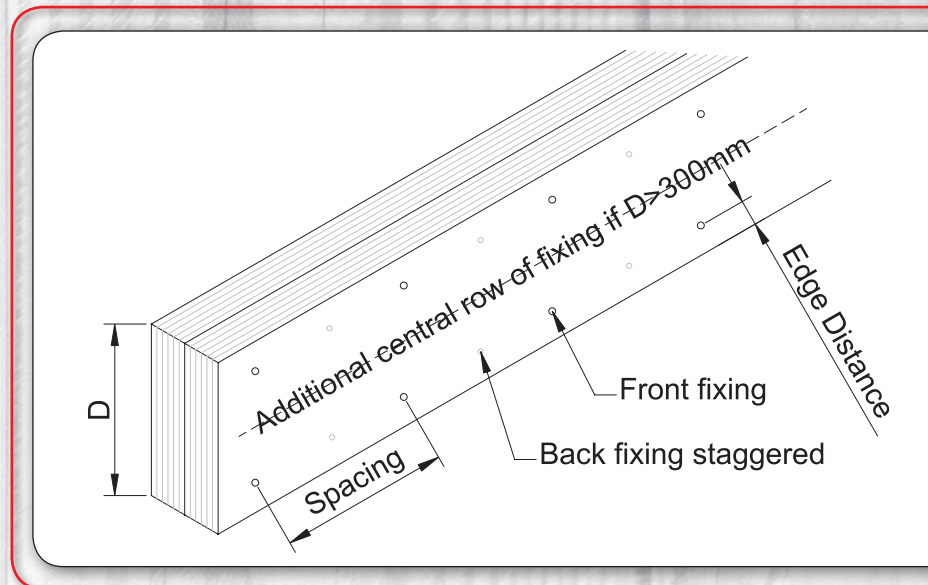

35mm LAMINATIONS

Fastener Type	Diameter	Length	Spacing	Min. Edge Distance
Nail	3.05mm	75mm	200mm	20mm
Screw	14g	75mm	300mm	35mm
Screw	SDWS	75mm	450mm	45mm
Bolt	M12		600mm	50mm

45mm LAMINATIONS

Fastener Type	Diameter	Length	Spacing	Min. Edge Distance
Nail	3.05mm	75mm	200mm	20mm
Screw	14g	90mm	300mm	35mm
Screw	SDWS	75mm	450mm	45mm
Bolt	M12		600mm	50mm

63mm/70mm LAMINATIONS

Fastener Type	Diameter	Length	Spacing	Min. Edge Distance
Nail	3.30mm	100mm	200mm	20mm
Screw	14g	100mm	300mm	35mm
Screw	SDWS	100mm	450mm	45mm
Bolt	M12		600mm	50mm

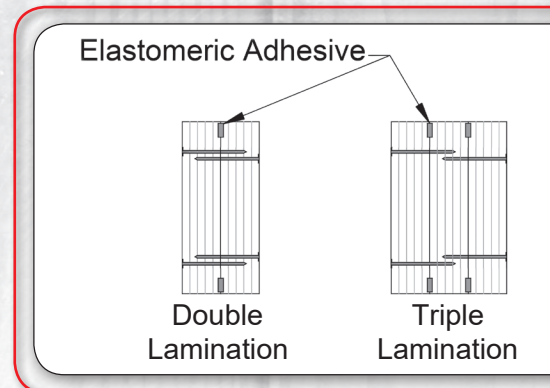

Meyer 
TIMBER®

Meyer Timber Pty Ltd.
Dana Court, Dandenong, VIC, 3172
Phone (03) 8710 6900

Meyer Timber QLD Pty Ltd.
Osprey Drive, Port of Brisbane, QLD, 4178
Phone (02) 3895 2222

Meyer Timber NSW Pty Ltd.
Castlereagh Rd, Penrith, NSW 2750
Phone (02) 4726 5900

www.meyertimber.com.au